

Dimensions: in.

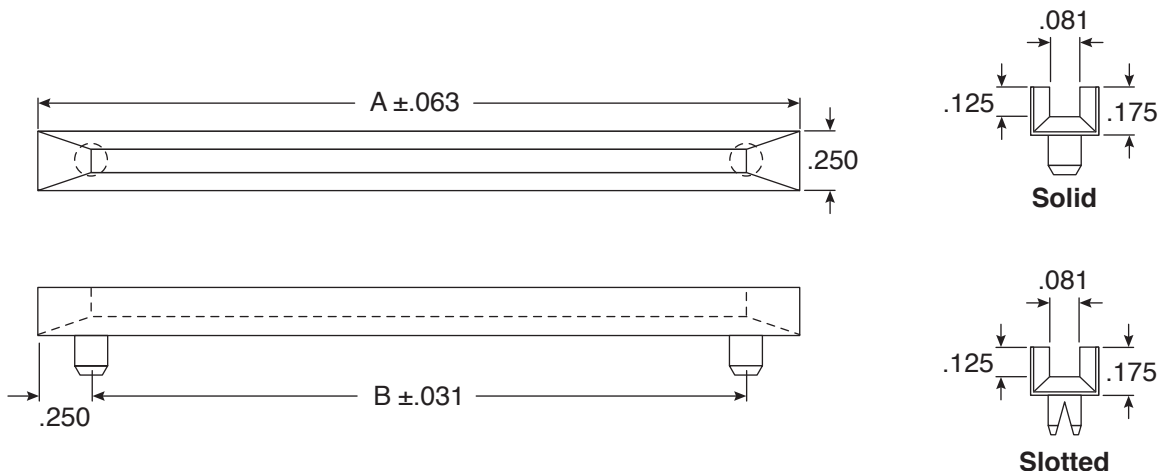

Printed circuit board support guides are an economical and fast solution to mount P.C. Boards. Card insertion is simple and fast. The smooth positive channel guides the P.C. Board and firmly supports and protects the board. Guides are molded of tough, electrically insulating nylon 6/6 and are designed to snap into pre-punched holes in the chassis.

The Printed Circuit Board Card Guide is designed to fit a .125" + .003" - .001" front diameter hole and a .120" +/- .005" x .218" slot rear hole.

Part Number	Description	Dimensions (in.)	
		A	B
561-CG250	2 1/2" Guide	2.5	2
561-0250WS	2 1/2" Guide w/ Split Legs	2.5	2
561-CG300	3" Guide	3	2.5
561-0300WS	3" Card Guide w/ Split Legs	3	2.5
561-CG350	3 1/2" Guide	3.5	3
561-CG400	4" Guide	4	3.5
561-0400WS	4" Card Guide w/ Split Legs	4	3.5
561-CG450	4 1/2" Guide	4.5	4
561-0450WS	4 1/2" Card Guide w/ Split Legs	4.5	4
561-0500G	5" Guide	5	4.5
561-0500WS	5" Card Guide w/ Split Legs	5	4.5
561-CG550	5 1/2" Guide	5.5	5
561-0550WS	5 1/2" Card Guide w/ Split Legs	5.5	5
561-CG600	6" Guide	6	5.5
561-0600WS	6" Card Guide w/ Split Legs	6	5.5

Available from Mouser Electronics
 1-800-346-6873
 www.mouser.com

EPD-200456